

Cash Drawer 1618

Cash Drawer has stainless steel housing with bullet resistant plastic drawer. Unit mounts in counter top along front edge. Glazing (by others) should set above the flat hood portion of drawer. As drawer slides out the stainless steel front panel pivots upward. Movement is controlled by the full width handle across rear of drawer. Lexan lid stays closed when drawer is extended. This unit is designed for long life as there are no slides to wear out.

Construction:

Housing: stainless steel
Drawer: bullet resistant plastic

Counter top opening size:

14.5" wide x 17.125" deep x 5.75" high

Drawer extension:

9"

Inside dimension of drawer:

12" wide x 14.625" deep x 3.625" high

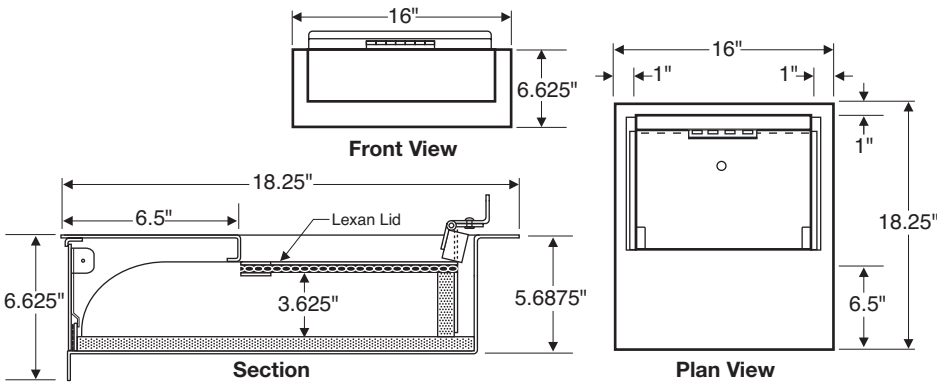

Transaction Drawer 1924-DD

1924-DD Transaction Drawer is bullet resistant and weather resistant. It is well suited for drive-up service. Drawer moves on heavy duty ball bearing slides and the front doors open as drawer is extended. The drawer locks automatically when closed. Lexan lid permits clear view inside drawer and remains closed when drawer is open to customer. Bill clip and coin pad are furnished inside drawer to hold currency. Drawer can be mounted in wall 1.0625" up to 8.625" thick.

Construction:

Drawer and housing: bullet resistant plastic
Doors, hood and flange: stainless steel

Inside drawer dimensions:

14.5" wide x 20" deep x 12" high

Drawer extension:

15.5"

Wall opening size:

19.25" wide x 16.5" high

Level I bullet resistant

